



Water to Water Modular Heat Pumps

EWV(H)(L)T-Q



Plug & play solution
for easier facility management

MODULAR WATER TO WATER HEAT PUMP

Plug & play solution for easier facility management



The range in numbers

- 3** Product versions:
- Heat pump with inversion on water side
 - Heat pump with inversion on refrigerant side (100 kW only)
 - Condenser-less

- 3** Base modules: 100 – 125 – 160 kW

- 98** Possible combinations of modules with the different product versions

Capacity range

Three base modules of 100, 125 and 160 kW. Modules can be combined up to 8 in two stacked arrays of 4, with resulting capacity range **from 200 to 1280 kW**

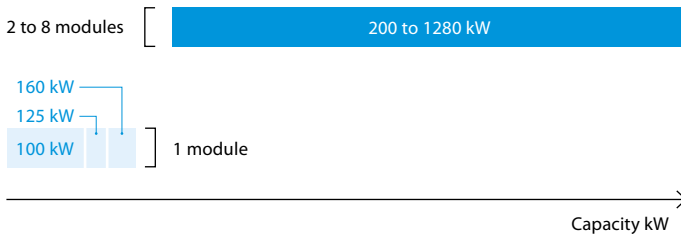

Operating range

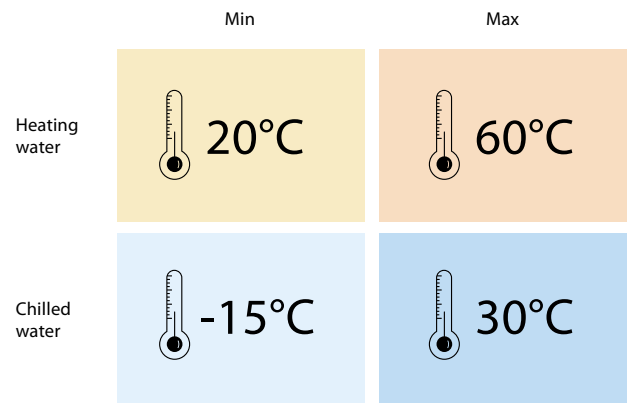

Product overview

- Indoor installation (xs)
- Outdoor installation (xr)
- Modular design
- Daikin VFD scroll compressors
- Braze plate heat exchangers
- R-32

The product features a new **modular approach** to system design, which introduces additional flexibility in configuration, allowing the required capacity to be reached by combining smaller units piped together and controlled as one. Consisting of three base modules with capacities of 100, 125 and 160kW, the range features **Daikin design** scroll compressors and R-32 refrigerant, whose GWP is 70% lower than that of R-410A. As well, R-32, being a pure and single component refrigerant, has all the characteristics needed to be easily recovered, recycled, or regenerated, so to enter the reclaimed refrigerant market and be reused. R-32 is also widely available on the market, as main refrigerant for air conditioning units with scroll compressors. That is, largely available for maintenance services.

The product is also available in two sound levels, including a reduced sound version suitable for outdoor installation and noise-sensitive applications such as residential buildings, hotels, and hospitals. Among the benefits, modular construction offers several advantages in siting and installation, making units easier to transport, handle, and install up to a fully plug-and-play solution by including the **Daikin Manifold Kit and Pump module**. Modules can be combined as a side-by-side array or stacked to minimise space requirements. Each of the different modules is very compact and can be easily transported and positioned in the installation space.

Product Benefits

Scalability & compactness

Due to its modularity, the new EW(W)(H)(L)T-Q A units offer high scalability potential. Modules can be added when needed, according to building's construction plan. As well, modules can be combined as a side-by-side array or stacked to minimise space requirements, particularly useful for retrofit applications. Modules

can be combined up to 8 in two stacked arrays of 4, with resulting capacity range **from 100 to 1280 kW**.



1



Max horizontal array: 4



Stackable up to 8 modules

Single Power Supply

As standard (no accessory) each module must be connected to a separate power supply. It is possible to have a single array (up to four modules) with a single power supply.

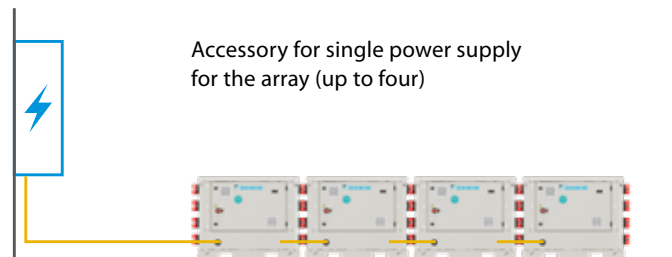
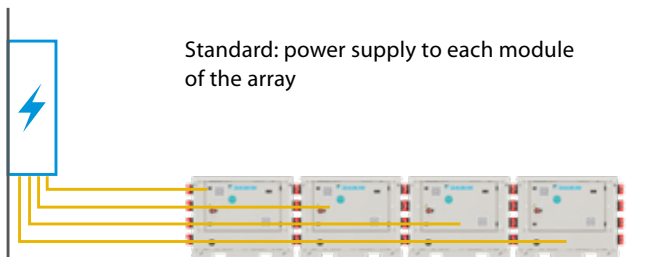

Busbars and cables are provided by factory with one of the below **accessories codes**. The electrical connection between modules must be done on site.

Accessory codes:

- EKSPFLT2 - Single Power Supply Kit for 2 modules
- EKSPFLT3 - Single Power Supply Kit for 3 modules
- EKSPFLT4 - Single Power Supply Kit for 4 modules

Attention:

- Single Power supply kit is shipped loose and to be mounted on site
- The stacked installation is not compatible with single power supply configuration
- Single power supply available only for indoor installation
- In case of 4 units on order, to be arranged in array, in case single power supply is required, EKSPFLT4 can be selected just one time

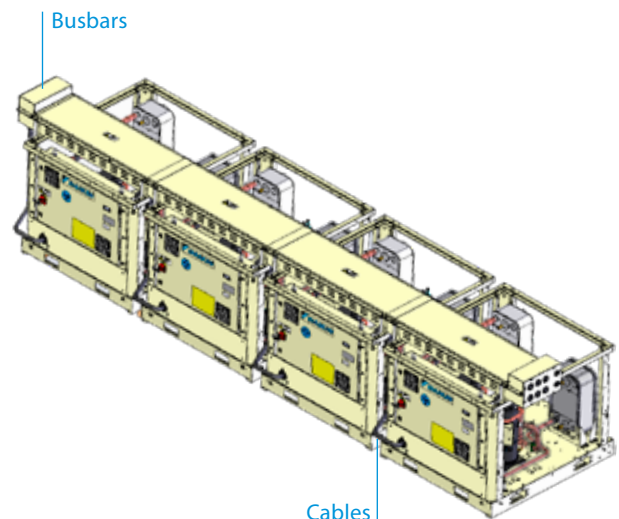

Plug & play installation

Simplified installation with the Manifold Kit, which is designed to connect modules on the waterside, as it includes the pipework between the units. The Manifold Kit can also be factory-mounted to further reduce installation time on site. In addition, a dedicated Pump Module can be easily added to the array of modules. It is equipped

with inverter pumps for full flexibility and includes an 18-litre expansion tank. For further easiness of installation, Single Power Supply can be integrated, having 1 single power cable connected to the array of up to 4 modules (cables connecting modules provided by factory).

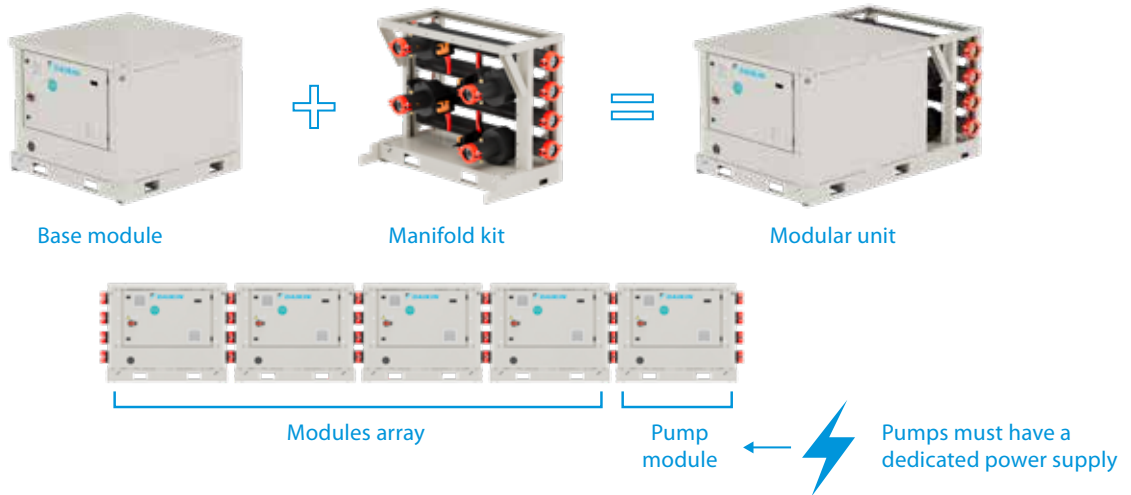

The modules can be installed indoor or even outdoor, if the reduced noise configuration would be selected. Indeed, the new EW(W)(H)(L)T-Q A offers two different noise configurations to comply with the requirements of noise sensitive applications as: residential, hotels and hospitals.

Lower operating costs

Thanks to its modular design, this new unit can closely follow the cooling and heating load profile of the building, according to EN14825. This is particularly important as it ensures low operating costs for the HVAC system at part load conditions, which represent most of the operating time. This is not the case with traditional packaged chillers & heat pumps, that need to work on a series of on-off cycles, reducing system efficiency.



Indoor installation



Outdoor installation

Limited environmental impact

The units use R-32 refrigerant, which has a Global Warming Potential (GWP) of 675, just one-third of R-410A. R-32 is a pure and single component refrigerant, so it can be reclaimed. A recent study from Tokyo City University* reports that reclaimed R-32 has an environmental impact 90% lower than virgin R-32, due to avoided need of destruction and lower energy required for reclamation with respect to new production. Daikin uses reclaimed R-32 on its chillers and heat pumps under its Loop by Daikin programme.



Contribution to Green Building

The most popular green building protocols are BREEAM and LEED. EW(W)(H)(L)T-Q A can contribute to a project's credits when evaluating energy efficiency of the hydronic system, especially if Partial Heat Recovery option would be selected. The limited GWP of R-32 and the low refrigerant charge per circuit thanks to the modular design also result in a possible contribution when evaluating the impact of refrigerants.



Product Applications

Heating

Space Heating + DHW configurations

- Centralized heating, eventually in water loop cascade with an air to water heat pump. DHW supply managed via independent DHW supply (single or array of modules dedicated to DHW, eventually stacked). Units can be managed in master / slave up to an array of 4 modules per master

- Residential, offices, Light commercial, gym, hotel
- Replacement and new building
- Possible terminals:
 - Radiators (up to 60 °C)
 - Heating floor (30-35 °C)
 - Fan coils (45 °C)

Centralized heating

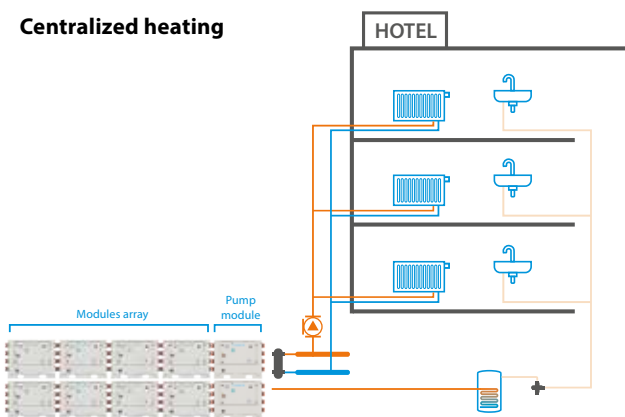

Water loop cascade

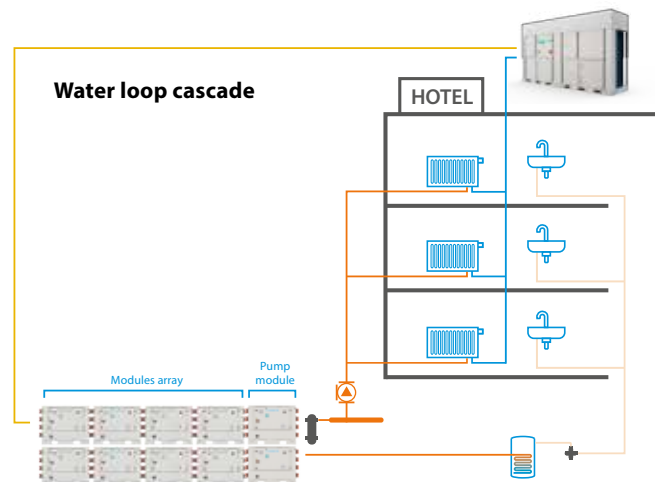

Cooling

Comfort cooling

- Centralized cooling. DHW managed via independent DHW supply (single or array of modules dedicated to DHW, eventually stacked). Units can be managed in master / slave up to an array of 4 modules per master
- Residential, offices, Light commercial, gym, hotel
- Replacement and new building
- Possible terminals:
 - Cooling floor (23-18 °C)
 - Fan coils (12-7 °C)

Process cooling

- Dedicated or centralized cooling according to project's needs. Units can be managed in master / slave up to an array of 4 modules per master
- Milk cooling (9-4 °C)
- Refrigerated warehouse (-8 to -12 °C, with glycol)
- MRI cooling, and many others

Comfort cooling

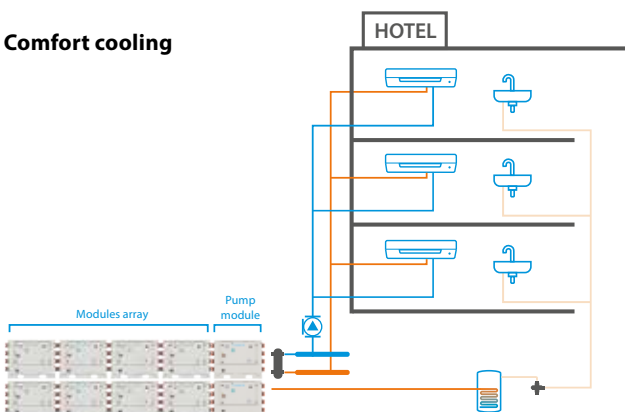

Process cooling

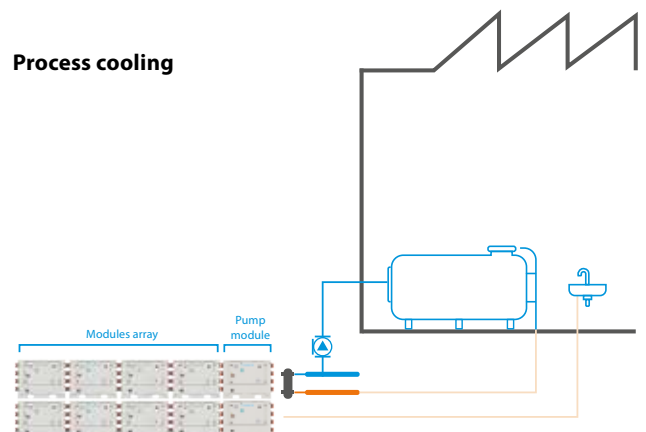

Product options and accessories

Options

Option	Description	EWWT-Q A	EWHT-Q A	EWLT-Q A
OPT03	Partial heat recovery	X	NA	NA
OPT07	Heat pump version with reversibility on water side	STD	STD	NA
OPT130	Evaporator and condenser victaulic kit	STD	STD	STD
OPT29	20mm evaporator insulation	STD	STD	STD
OPT33	20mm condenser insulation	X	STD	NA
OPT60	Electronic expansion valve	STD	STD	STD
OPT127	High and low pressure side manometers	X	X	X
OPT91	Double pressure relief valve with diverter	X	X	X
OPT04	Dol starter	STD	STD	STD
OPT66	Set point reset	STD	STD	STD
OPT66a	Demand limit	STD	STD	STD
OPT15	Under / over voltage control	X	X	X
OPT17	Capacitors for power factor correction	X	X	X
OPT58	Evaporator flow switch	STD	STD	STD
OPT59	Condenser flow switch	X	STD	NA
OPT68	Hour run meter	STD	STD	STD
OPT69	General fault contactor	STD	STD	STD
OPT95	Compressors circuit breakers	X	X	X
OPT97	Main switch interlock door	STD	STD	STD
OPT102	Ground fault relay	X	X	X
OPT128	Master/slave	STD	STD	STD
OPT180	Modbus RTU MSTP	STD	STD	STD
OPT188	Heating only mode	SO	NA	NA
OPT75	Rubber anti vibration mounts	X	X	X
OPT112	Transport kit	STD	STD	STD

Accessories

Accessory code	Description	EWWT-Q A	EWHT-Q A	EWLT-Q A
EKCBMS	Connectivity for external BMS communication (modbus TCP, bacnet MSTP/IP)	X	X	X
EKSCDP	Differential pressure trasducer for VPF	X	X	X
EKDOSMWO	Daikin on site modem without M2M card	X	X	X
EKRSCPCS	Local/remote display external HMI	X	X	X
EKRUPCS	Local/remote display HMI	X	X	X
EKMFKIT3	Manifold module 3"	X	X	NA
EKMFKIT5	Manifold module 5"	X	X	NA
EKWCONNKIT3	EWWT-Q A connection kit 3"	X	NA	NA
EKHCONNKIT3	EWHT-Q A connection kit 3"	NA	X	NA
EKWCONNKIT5	EWWT-Q A connection kit 5"	X	NA	NA
EKHCONNKIT5	EWHT-Q A connection kit 5"	NA	X	NA
EKPUMPLL1	Pump module vfd low lift cool 3.3 -9.4 heat 5.3-11.1	X	X	NA
EKPUMPLL2	Pump module vfd low lift cool 9.5 -15.5 heat 11.2-19	X	X	NA
EKPUMPLL3	Pump module vfd low lift cool 15.6-19.5 heat 19.1-23	X	X	NA
EKPUMPLL4	Pump module vfd low lift cool 19.6 -23.1 heat 23.1-27.7	X	X	NA
EKPUMPLL5	Pump module vfd low lift cool 23.2 -28.6 heat 27.8-34.7	X	X	NA
EKPUMPHL1	Pump module with vfd high lift cool 3.3 -11.6 heat 5.3-13.9	X	X	NA
EKPUMPHL2	Pump module with vfd high lift cool 11.7-15.5 heat 14-19	X	X	NA
EKPUMPHL3	Pump module with vfd high lift cool 15.6-20.8 heat 19.1-24.2	X	X	NA
EKPUMPHL4	Pump module with vfd high lift cool 20.9-29.6 heat 24.3-34.7	X	X	NA
EKRUBAVMC	Rubber anti vibration mounts per manifold	X	X	NA
EKRUBAVMP	Rubber anti vibration mounts per pump kit	X	X	NA
EKWTRFLTR3	Water filter 3"	X	X	X
EKWTRFLTR5	Water filter 5"	X	X	X
EKVPFKIT	Kit for variable primary flow systems on one loop only (for multiple units)	X	X	X
EKSPELT2	Single power supply kit for 2 modules	X	X	X
EKSPELT3	Single power supply kit for 3 modules	X	X	X
EKSPELT4	Single power supply kit for 4 modules	X	X	X
EKCTRLPACK	Control extension pack: alarm from external device; double set-point	X	X	X
EKICMGW	i-CM gateway (multi master controller)	X	X	X
EKSTCK	Stacked installation kit	X	X	X
EKSBSM	Monifold module kit	X	X	X
EKACTV	Motorized valve	X	X	X
EKRUBPAD	4x rubber pad 150x240	X	X	X
EKWIO	Kit water in/out	X	X	X

STD: Provided as standard

X: On demand

NA: Not available

Product special kits

Manifold Kit

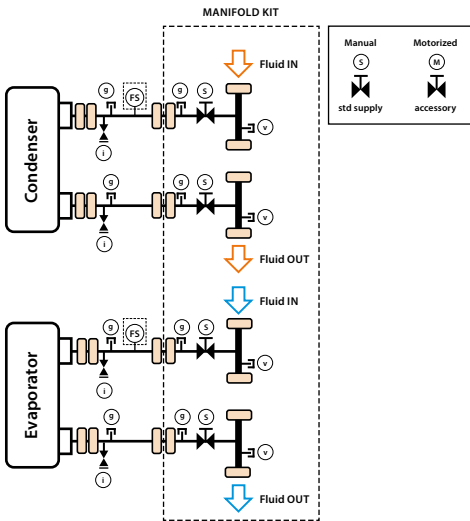

Legend	
g	Plugged Fitting 1/4" NPT
FS	Flow Switch
i	Drain 1/2" NPT
s	Isolating valve. Standard with Manual control, motorized actuator available as accessory
v	Probe socket

Pump module

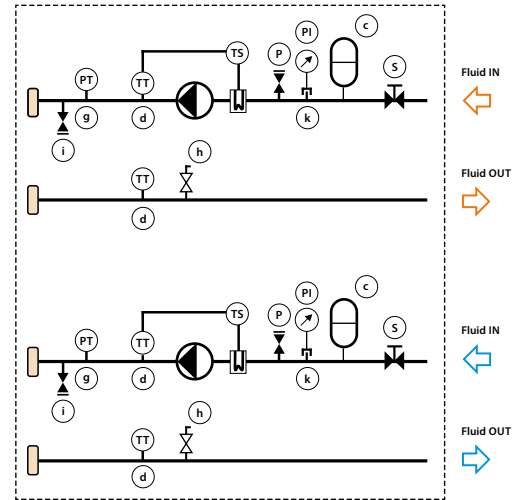

Legend	
g	Plugged Fitting 1/4" NPT
TT	Temperature Transducer
i	Drain 1/2" NPT
s	Isolating valve
c	Expansion tank 18 lt
PT	Pressure transducer
TS	Temperature Switch
PI	Pressure gauge
h	Air vent
k	Electrical heater
d	Plugged fitting 1/2" NPT

Pump curves

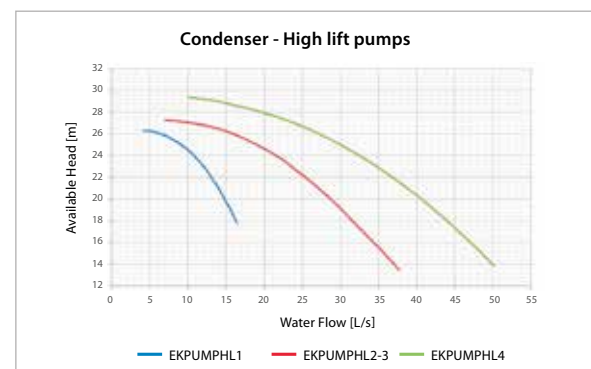
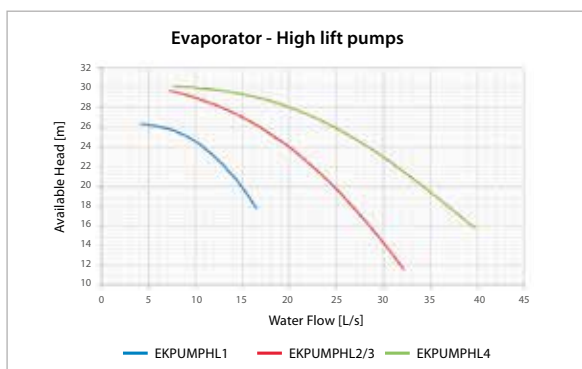
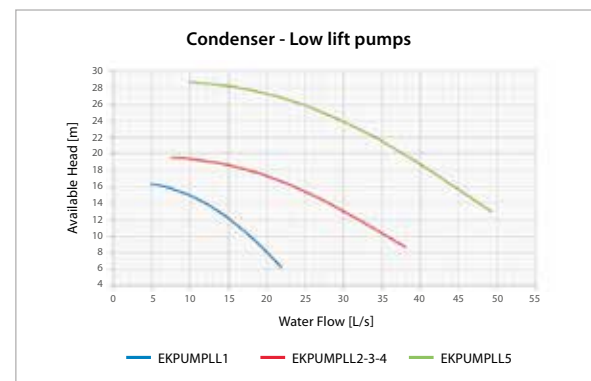
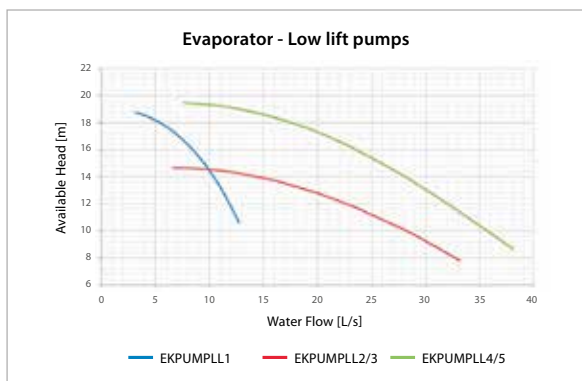

Note: installation of filter and flow switch is mandatory. Circuit must be protected from freezing.

Product dimensions & modular arrays

Single module



Stacked 4+4 with manifold



Modules Array	Length (mm)	Width (mm)	Height (mm)
Single module	1300	1200	1000
Array of 2 with manifold	1300	2400	1000
Stacked 1+1 no manifold	1300	1200	2000
Array of 3 with manifold	1300	3600	1000
Stacked 2+1 no manifold	1300	2400	2000
Array of 4 with manifold	1300	4800	1000
Stacked 2+2 with manifold	1300	2400	2000
Stacked 3+2 with manifold	1300	3600	2000
Stacked 3+3 with manifold	1300	3600	2000
Stacked 4+3 with manifold	1300	4800	2000
Stacked 4+4 with manifold	1300	4800	2000

Minimum space required for maintenance
Scale 1:50/1:50

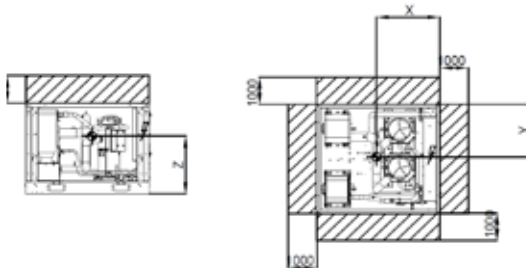

Isolator location (bottom view)
Scale 1:50/1:50

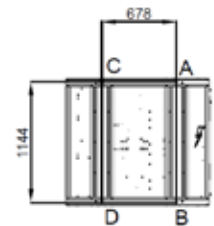

Isolator loads [kg]

UNIT	EWWT100Q-X		EWWT125Q-X		EWWT160Q-X		EHWT100Q-X		EWLT100Q-X		EWLT125Q-X		EWLT160Q-X	
	SA1	RA1	SA1	RA1	SA1	RA1	SA1	RA1	SA1	RA1	SA1	RA1	SA1	RA1
A	106	118	127	139	132	148	107	118	112	118	135	140	140	145
B	133	140	139	147	168	172	133	140	134	150	144	158	172	185
C	99	112	115	128	130	141	105	118	48	67	56	78	59	79
D	101	120	110	128	131	151	106	126	88	98	92	104	111	124

Plant water content

As a general indication, the system water content should not be less than the values deriving from the following formula:

Minimum water content per base module $\rightarrow 5 \frac{It}{kW_{nominal}}$

$kW_{nominal} = \text{Cooling capacity at } 12/7^{\circ}\text{C} \mid 30/35^{\circ}\text{C}$

The above rule of thumb derives from the following formula, as the relative volume of water capable of maintaining the water temperature setpoint differential during the minimum load transient avoiding an excessive starts and stops of the compressor itself (which depends on the compressor technology):

Water volume = $\frac{CC [W] * \text{Min load \%} * DNCS [s]}{FD \left[\frac{g}{L}\right] * SH \left[\frac{J}{g^{\circ}C}\right] * (DT)[^{\circ}C]}$

CC = Cooling Capacity

DNCS = Delay to next Compressor Start

FD = Fluid Density

SH Specific Heat

DT = Water Temperature Setpoint Differential

A properly designed storage tank should be added if the system components do not provide sufficient water volume. By default, the unit is set to have a water temperature setpoint differential in line with Comfort Cooling and Heating application which allows to operate with the minimum volume mentioned in the previous formula.

However, if a smaller temperature differential is set, as in the case of Process Cooling applications where temperature fluctuations must be avoided, a larger minimum water volume will be required.

To ensure proper operation of the unit when changing the value of setting, the minimum water volume must be corrected.

In case of more than one installed unit, the overall capacity of the installation must be considered in the calculation so summing the water content of each unit.

Product technical data

Water to water heat pump

Technical specifications				EWWT100Q-XSA1	EWWT125Q-XSA1	EWWT160Q-XSA1	EWWT100Q-XRA1	EWWT125Q-XRA1	EWWT160Q-XRA1	
Cooling capacity	Nom.		kW	96.36	124.4	166.0	96.36	124.4	166.0	
Heating capacity	Nom.		kW	110.2	142.8	186.7	110.2	142.8	186.7	
Capacity control	Method			On/Off						
	Minimum capacity		%	50						
Power input	Cooling	Nom.	kW	20.99	27.95	34.44	20.99	27.95	34.44	
	Heating	Nom.	kW	26.11	34.49	42.53	26.11	34.49	42.53	
EER				4.59	4.45	4.82	4.59	4.45	4.82	
COP				4.22	4.14	4.39	4.22	4.14	4.39	
IPLV				7.15	7.12	7.41	7.15	7.12	7.41	
SCOP				4.72	4.81	4.94	4.72	4.81	4.94	
SEER				6.4	6.54	6.49	6.4	6.54	6.49	
Dimensions	Unit	Depth	mm	1,300						
		Height	mm	1,000						
		Width	mm	1,200						
Weight	Operation weight		kg	439	491	561	490	542	612	
	Unit		kg	419	469	531	470	520	582	
Casing	Colour			Ivory White						
	Material			Galvanized Steel Sheet						
Water heat exchanger	Type			Braze Plate						
	Water flow rate	Cooling	Nom.	l/s	4.60	5.93	7.92	4.60	5.93	7.92
		Heating	Nom.	l/s	5.27	6.82	8.92	5.27	6.82	8.92
	Water pressure drop	Cooling	Nom.	l/s	19.35	20.00	22.10	19.35	20.00	22.10
		Heating	Nom.	l/s	24.90	25.10	29.70	24.90	25.10	29.70
Water volume			l	9.45	11.07	14.85	9.45	11.07	14.85	
Water heat exchanger - evaporator	Water flow rate	Cooling	Nom.	l/s	4.60	5.93	7.92	4.60	5.93	7.92
		Heating	Nom.	l/s	5.60	7.26	9.55	5.60	7.26	9.55
	Water pressure drop	Cooling	Nom.	l/s	19.35	19.98	22.15	19.35	19.98	22.15
		Heating	Nom.	l/s	27.81	28.00	33.60	27.81	28.00	33.60
Compressor	Quantity			2						
	Type			Scroll						
	Oil	Charged volume		l	6	7.5	9	6	7.5	9
Operation range	Water side	Evaporator Min.		°CDB	-15					
		Max.		°CDB	30					
	Condenser	Min.		°CDB	20					
		Max.		°CDB	60					
Sound power level	Cooling	Nom.	dBA	81.0	84.2	86.0	75.0	78.2	80.0	
	Heating	Nom.	dBA	65.4	68.6	70.4	59.4	62.6	64.4	
Sound pressure level	Cooling	Nom.	dBA	65.4	68.6	70.4	59.4	62.6	64.4	
Refrigerant	Type			R32						
	GWP			675						
	Charge			kg	6	7.1	10.3	6	7.1	10.3
	Circuits		Quantity		1					
Piping connections	Evaporator water inlet/outlet (OD)			3"						
Electrical specifications				EWWT100Q-XSA1	EWWT125Q-XSA1	EWWT160Q-XSA1	EWWT100Q-XRA1	EWWT125Q-XRA1	EWWT160Q-XRA1	
Power supply	Phase			3						
	Frequency			Hz	50					
	Voltage			V	400					
	Voltage range	Min.		%	-10					
		Max.		%	+10					
Unit	Starting current	Max		A	221	345	363	221	345	363
	Running current	Cooling	Nom.	A	36.6	44.2	52.6	36.6	44.2	52.6
		Max		A	62	80	97	62	80	97
	Max unit current for wires sizing			A	68	88	107	68	88	107

Product technical data

Water to water heat pump

Technical specifications					EWHT100Q-XSA1		EWHT100Q-XRA1		
Cooling capacity	Nom.			kW				91.68	
Heating capacity	Nom.			kW				106.0	
Capacity control	Method							On/Off	
	Minimum capacity			%				50	
Power input	Cooling	Nom.		kW				21.22	
	Heating	Nom.		kW				26.3	
EER								4.32	
COP								4.03	
IPLV								6.66	
SCOP								4.55	
SEER								5.98	
Dimensions	Unit	Depth		mm				1,300	
		Height		mm				1,000	
		Width		mm				1,200	
Weight	Operation weight			kg	451			502	
	Unit			kg	431			482	
Casing	Colour							Ivory White	
	Material							Galvanized Steel Sheet	
Water heat exchanger	Type							Brazed Plate	
	Water flow rate	Cooling	Nom.	l/s				4.37	
		Heating	Nom.	l/s				5.07	
	Water pressure drop	Cooling	Nom.	l/s				17.70	
		Heating	Nom.	l/s				23.20	
	Water volume			l				9.45	
Water heat exchanger - evaporator	Water flow rate	Cooling	Nom.	l/s				4.37	
		Heating	Nom.	l/s				5.39	
	Water pressure drop	Cooling	Nom.	l/s				17.70	
		Heating	Nom.	l/s				25.90	
Compressor	Quantity							2	
	Type							Scroll	
	Oil	Charged volume		l				6	
Operation range	Water side	Evaporator	Min.	°CDB				-15	
			Max.	°CDB				30	
	Condenser	Min.	°CDB					20	
		Max.	°CDB					60	
Sound power level	Cooling	Nom.		dBA	81.0			75.0	
Sound pressure level	Cooling	Nom.		dBA	65.4			59.4	
Refrigerant	Type							R32	
	GWP							675	
	Charge			kg				7	
	Circuits	Quantity						1	
Piping connections	Evaporator water inlet/outlet (OD)							3"	
Electrical specifications					EWHT100Q-XSA1		EWHT100Q-XRA1		
Power supply	Phase							3	
	Frequency			Hz				50	
	Voltage			V				400	
	Voltage range	Min.			%				-10
		Max.			%				+10
Unit	Starting current	Max		A				221	
	Running current	Cooling	Nom.	A				36.9	
		Max		A				62	
	Max unit current for wires sizing			A				68	

Product technical data

Condenserless unit

Technical specifications				EWLT100Q- XSA1	EWLT125Q- XSA1	EWLT160Q- XSA1	EWLT100Q- XRA1	EWLT125Q- XRA1	EWLT160Q- XRA1	
Cooling capacity	Nom.		kW	90.2	116.9	155	90.2	116.9	155	
Heating capacity	Nom.		kW	-						
Capacity control	Method			On/Off						
	Minimum capacity		%	50						
Power input	Cooling	Nom.	kW	23.67	31.1	38.55	23.67	31.1	38.55	
	Heating	Nom.	kW	-						
EER				3.81	3.76	4.02	3.81	3.76	4.02	
COP				-						
IPLV				-						
SCOP				-						
SEER				-						
Dimensions	Unit	Depth	mm	1,300						
		Height	mm	1,000						
		Width	mm	1,200						
Weight	Operation weight		kg	382	428	482	433	479	533	
	Unit		kg	372	417	467	423	468	518	
Casing	Colour			Ivory White						
	Material			Galvanized Steel Sheet						
Water heat exchanger	Type			Braze Plate						
	Water flow rate	Cooling	Nom.	l/s	4.3	5.58	7.39	4.3	5.58	7.39
		Heating	Nom.	l/s	-					
	Water pressure drop	Cooling	Nom.	l/s	17.16	17.93	19.55	17.16	17.93	19.55
		Heating	Nom.	l/s	-					
Water volume			l	9.45	11.07	14.85	9.45	11.07	14.85	
Water heat exchanger - evaporator	Water flow rate	Cooling	Nom.	l/s	4.3	5.58	7.39	4.3	5.58	7.39
		Heating	Nom.	l/s	-					
	Water pressure drop	Cooling	Nom.	l/s	17.16	17.93	19.55	17.16	17.93	19.55
		Heating	Nom.	l/s	-					
Compressor	Quantity			2						
	Type			Scroll						
	Oil	Charged volume	l	6	7.5	9	6	7.5	9	
Operation range	Water side	Evaporator	Min.	°CDB	-15					
			Max.	°CDB	30					
	Condenser	Min.	°CDB	20						
		Max.	°CDB	60						
Sound power level	Cooling	Nom.	dBA	81.0	84.2	86.0	75.0	78.2	80.0	
Sound pressure level	Cooling	Nom.	dBA	65.4	68.6	70.4	59.4	62.6	64.4	
Refrigerant	Type			R32						
	GWP			675						
	Charge		kg	0						
	Circuits	Quantity		1						
Piping connections	Evaporator water inlet/outlet (OD)			3"						
Electrical specifications				EWLT100Q- XSA1	EWLT125Q- XSA1	EWLT160Q- XSA1	EWLT100Q- XRA1	EWLT125Q- XRA1	EWLT160Q- XRA1	
Power supply	Phase			3						
	Frequency		Hz	50						
	Voltage		V	400						
	Voltage range	Min.	%	-10						
		Max.	%	+10						
Unit	Starting current		A	221	345	363	221	345	363	
	Running current	Cooling	Nom.	A	42.1	50	60.7	42.1	50	60.7
		Max		A	62	80	97	62	80	97
	Max unit current for wires sizing		A	68	88	107	68	88	107	

Product sound power & pressure details

	EWHT-Q-XS			EWHT-Q-XS	EWLT-Q-XS			EWWT-Q-XR			EWHT-Q-XR	EWLT-Q-XR			
	100	125	160	100	100	125	160	100	125	160	100	100	125	160	
Sound pressure level @ 1 m from the unit (rif. 2 x10 ⁻⁵ Pa)	63 Hz	64,8	68	69,8	64,8	64,8	68	69,8	58,8	62	63,8	58,8	58,8	62	63,8
	125 Hz	71,5	74,7	76,5	71,5	71,5	74,7	76,5	65,5	68,7	70,5	65,5	65,5	68,7	70,5
	250 Hz	72,3	75,5	77,3	72,3	72,3	75,5	77,3	66,3	69,5	71,3	66,3	66,3	69,5	71,3
	500 Hz	71,9	75,1	76,9	71,9	71,9	75,1	76,9	65,9	69,1	70,9	65,9	65,9	69,1	70,9
	1000 Hz	73,5	76,7	78,5	73,5	73,5	76,7	78,5	67,5	70,7	72,5	67,5	67,5	70,7	72,5
	2000 Hz	77,9	81,1	82,9	77,9	77,9	81,1	82,9	71,9	75,1	76,9	71,9	71,9	75,1	76,9
	4000 Hz	69,7	72,9	74,7	69,7	69,7	72,9	74,7	63,7	66,9	68,7	63,7	63,7	66,9	68,7
	8000 Hz	60,4	63,6	65,4	60,4	60,4	63,6	65,4	54,4	57,6	59,4	54,4	54,4	57,6	59,4
Sound pressure Lp @ 1 m	65,4	68,6	70,4	65,4	65,4	68,6	70,4	59,4	62,6	64,4	59,4	59,4	62,6	64,4	
Sound power Lw	81	84,2	86	81	81	84,2	86	75	78,2	80	75	75	78,2	80	
Sound pressure - Lp [dB(A)] at	1 m	65,4	68,6	70,4	65,4	65,4	68,6	70,4	59,4	62,6	64,4	59,4	59,4	62,6	64,4
	2 m	61,4	64,6	66,4	61,4	61,4	64,6	66,4	55,4	58,6	60,4	55,4	55,4	58,6	60,4
	3 m	58,7	61,9	63,7	58,7	58,7	61,9	63,7	52,7	55,9	57,7	52,7	52,7	55,9	57,7
	4 m	56,7	59,9	61,7	56,7	56,7	59,9	61,7	50,7	53,9	55,7	50,7	50,7	53,9	55,7
	5 m	55	58,2	60	55	55	58,2	60	49	52,2	54	49	49	52,2	54
	6 m	53,6	56,8	58,6	53,6	53,6	56,8	58,6	47,6	50,8	52,6	47,6	47,6	50,8	52,6
	7 m	52,4	55,6	57,4	52,4	52,4	55,6	57,4	46,4	49,6	51,4	46,4	46,4	49,6	51,4
	8 m	51,4	54,6	56,4	51,4	51,4	54,6	56,4	45,4	48,6	50,4	45,4	45,4	48,6	50,4
	9 m	50,4	53,6	55,4	50,4	50,4	53,6	55,4	44,4	47,6	49,4	44,4	44,4	47,6	49,4
	10 m	49,6	52,8	54,6	49,6	49,6	52,8	54,6	43,6	46,8	48,6	43,6	43,6	46,8	48,6

- i) The above data are referred to the unit without additional optional.
- ii) The above data are referred the unit installed in compliancy with installation prescription.
- iii) All the data are subject to change without notice. For updated information on project base refer to Chiller Selection Software and unit's certified drawing.
- iv) Sound data in the Octave band spectrum and sound pressure over 1 m are based on calculation, thus intended as general guideline, and not considered binding.

Standard Rating Conditions for Water-to-Water chillers according to EN14511:2. Outdoor Heat exchanger inlet temperature 30°C, outlet 35°C; Indoor heat exchanger inlet temperature 12°C, outlet temperature 7°C. Fluid: water, fouling factor = 0 Sound Power levels are measured in accordance with ISO 9614. Sound Pressure at levels 1 meter are measured in accordance with ISO 3744

